



晶采光電科技股份有限公司  
AMPIRE CO., LTD.

## SPECIFICATIONS FOR LCD MODULE

<b>CUSTOMER</b>	
<b>CUSTOMER PART NO.</b>	
<b>AMPIRE PART NO.</b>	<b>AC-162DYILY-57H-A(R)</b>
<b>APPROVED BY</b>	
<b>DATE</b>	

- Approved For Specifications  
 Approved For Specifications & Sample

**AMPIRE CO., LTD.**

**Building D., 2F., No.88, Sec. 1, Sintai 5th Rd., Sijhih City,  
Taipei County 221, Taiwan (R.O.C.)**

**台北縣汐止市新台五路一段 88 號 2 樓(東方科學園區 D 棟)**

**TEL:886-2-26967269 , FAX:886-2-86967196 or 26967270**

<b>APPROVED BY</b>	<b>CHECKED BY</b>	<b>ORGANIZED BY</b>

## RECORD OF REVISION

<b>Revision Date</b>	<b>Page</b>	<b>Contents</b>	<b>Editor</b>
2010/08/27	-	New Release	Emil

## 1 FEATURES

- (1) Display format : 16 characters × 2 lines
- (2) Construction : STN LCD panel, Bezel, Zebra , Yellow-green LED Back-light and PCB.
- (3) Display type : STN, Yellow-green mode, Transflective , 6 o'clock view.
- (4) Controller : ST7066-0A
- (5) 5V single power input.
- (6) Extended temperature type.
- (7) Excellent LC : VOP maintains at 5V for whole temp. range, no need extra temp. compensation circuit.
- (8) Interface **Pin15=K , Pin16=A.**
- (9) ROHS compliant.

## 2 MECHANICAL DATA

Parameter	Stand Value	Unit
Dot size	0.55(W) × 0.65(H)	mm
Dot pitch	0.60(W) × 0.70(H)	mm
Character size	2.95(W) × 5.55(H)	mm
Viewing area	64.0(W) × 17.2(H)	mm
Module size (with LED Backlight)	84.0(W) × 44.0(H) × 14.5 max (T)	mm

## 3 ABSOLUTE MAXIMUM RATINGS

Parameter	Symbol	Min	Max	Unit	
Logic Circuit Supply Voltage	VDD-VSS	-0.3	7.0	V	
LCD Driving Voltage	VDD-VO	-0.3	10.0	V	
Input Voltage	VI	-0.3	VDD+0.3	V	
Extended temp. type	Operating Temp.	TOP	-20	70	°C
	Storage Temp.	TSTG	-30	80	°C

## 4 ELECTRO-OPTICAL CHARACTERISTICS

Parameter	Symbol	Condition	Min	Typ	Max	Unit	Note
<b>----- Electronic Characteristics -----</b>							
LCD Driving Voltage ( STN )	VDD-VO	-20°C	4.75	5.0	5.25	V	
		25 °C	4.75	5.0	5.25		
		-70 °C	4.75	5.0	5.25		
Input Voltage	VIH	--	0.7 VDD	--	VDD	V	
	VIL	--	VSS	--	0.3 VDD	V	
Logic Supply Current	IDD	VDD = 5V	--	1.2	1.6	mA	
<b>----- Optical Characteristics ( STN ) -----</b>							
Contrast	CR	25°C	--	5	--		Note 1
Rise Time	tr	25°C	--	200	300	ms	Note 2
Fall Time	tf	25°C	--	200	300	ms	
Viewing Angle Range	θ f	25°C & CR≥2	--	40	--	Deg.	Note 3
	θ b		--	35	--		
	θ l		--	35	--		
	θ r		--	35	--		
Frame Frequency	fF	25°C	--	64	--	Hz	
<b>-----Array type LED Back-light Characteristics -----</b>							
Parameter	Symbol	Condition	Min	Typ	Max	Unit	Note
Forward Voltage	VF	--	--	4.05	4.3	V	Supply Voltage between A&K
Forward Current	IF	VF=4.05V	--	120	--	mA	
LCM Luminous intensity		VF=4.05V	--	30	--	cd/m <sup>2</sup>	

\* LED Dice number = 2×12=24

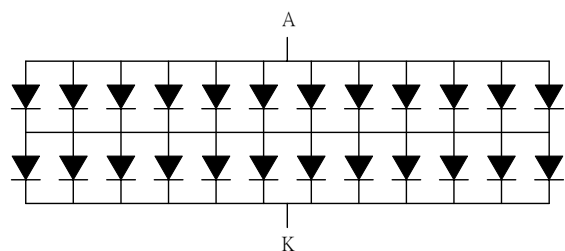

(NOTE 1) Contrast ratio :

$$CR = (\text{Brightness in OFF state}) / (\text{Brightness in ON state})$$

(NOTE 2) Response time :

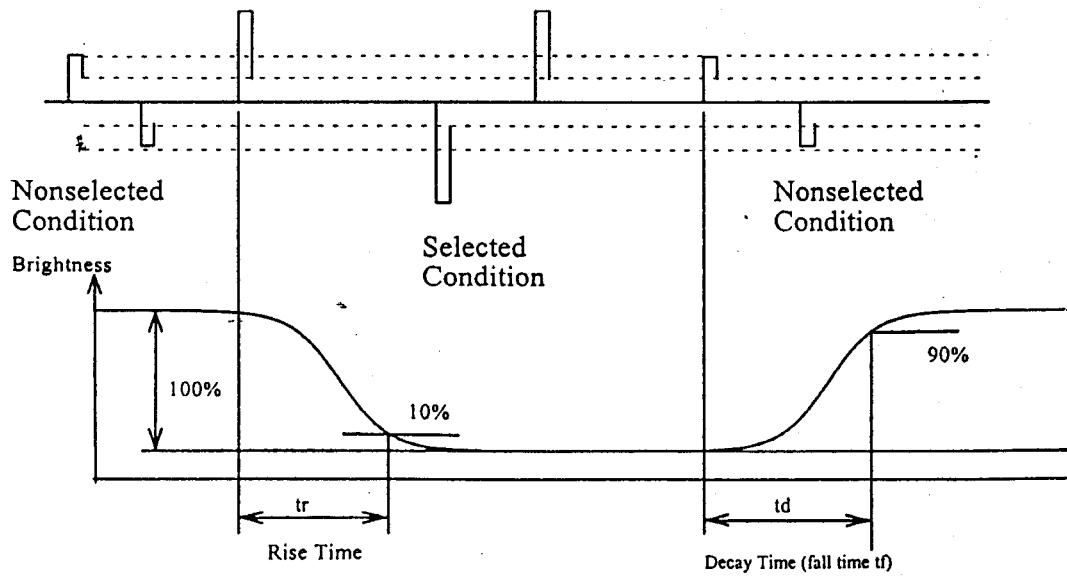

(NOTE 3) Viewing angle

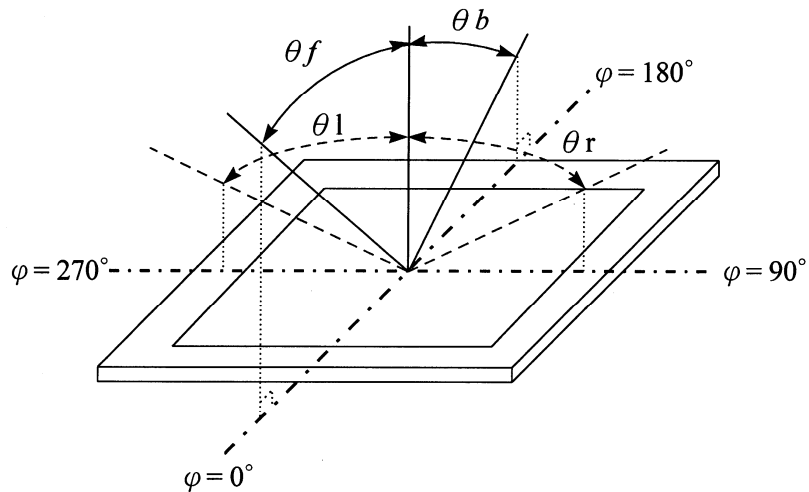

## 5 BLOCK DIAGRAM & INTERFACE

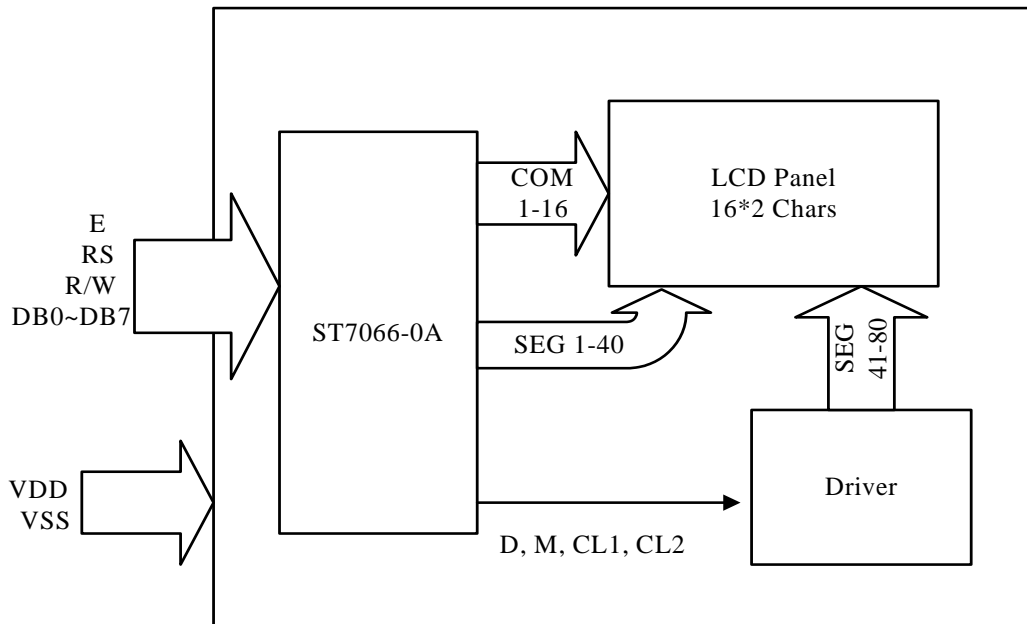

No.	Symbol	Function
1	VSS	Ground (0V)
2	VDD	Supply Voltage for Logic (+5V)
3	VO	Contrast Adjustment
4	RS	Data/Instruction Select
5	R/W	Read/Write Select
6	E	Enable Signal
7	DB0	Data Bus
8	DB1	Data Bus
9	DB2	Data Bus
10	DB3	Data Bus
11	DB4	Data Bus
12	DB5	Data Bus
13	DB6	Data Bus
14	DB7	Data Bus
15	LED_K	LED Supply Voltage - (5V)
16	LED_A	LED Supply Voltage + (5V)

# 6 POWER SUPPLY

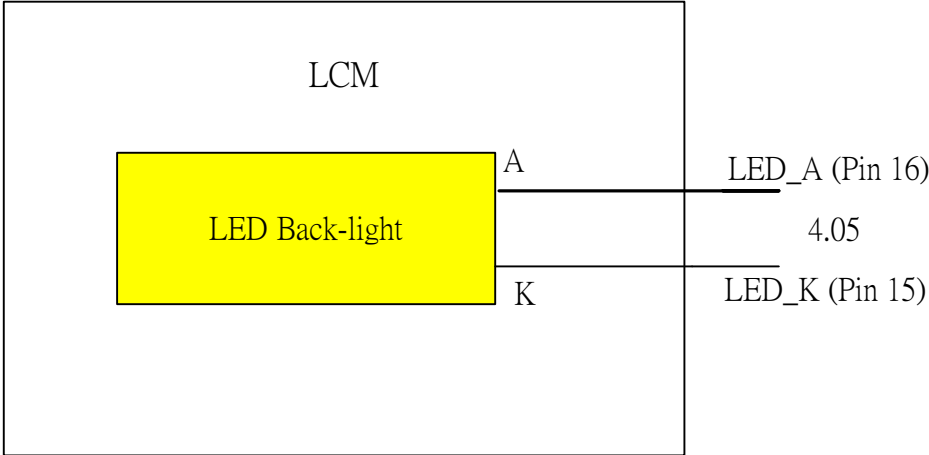
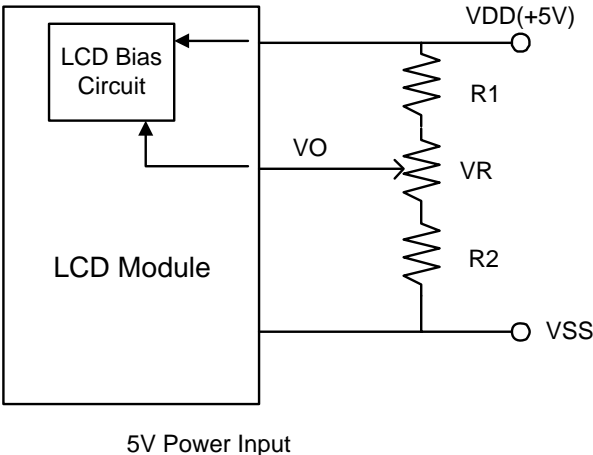

## 7 TIMING CHARACTERISTICS

### Write Operation

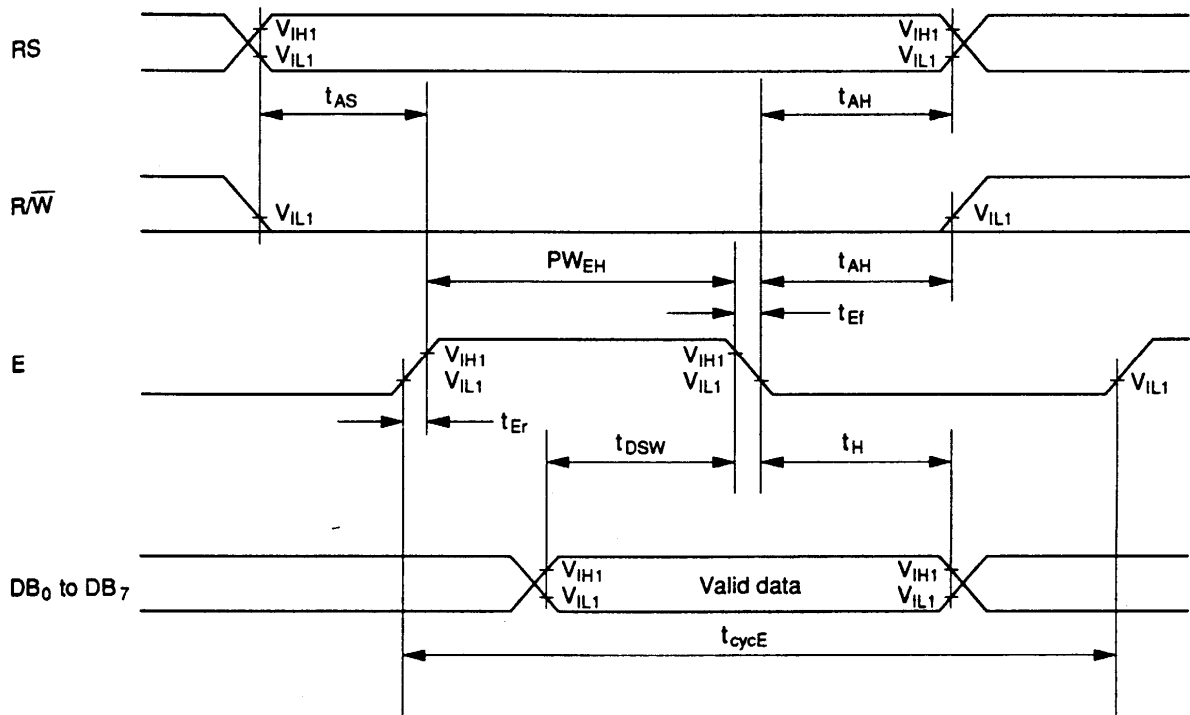

Item	Symbol	VDD=5V		Unit
		Min	Max	
Enable cycle time	$t_{cycE}$	1200	--	ns
Enable pulse width	$PW_{EH}$	140	--	
Enable rise/fall time	$t_{Er}, t_{Ef}$	--	25	
Address set-up time (RS, R/W to E)	$t_{AS}$	0	--	
Address hold time	$t_{AH}$	10	--	
Data set-up time	$t_{Dsw}$	40	--	
Data hold time	$t_H$	10	--	



## Read Operation

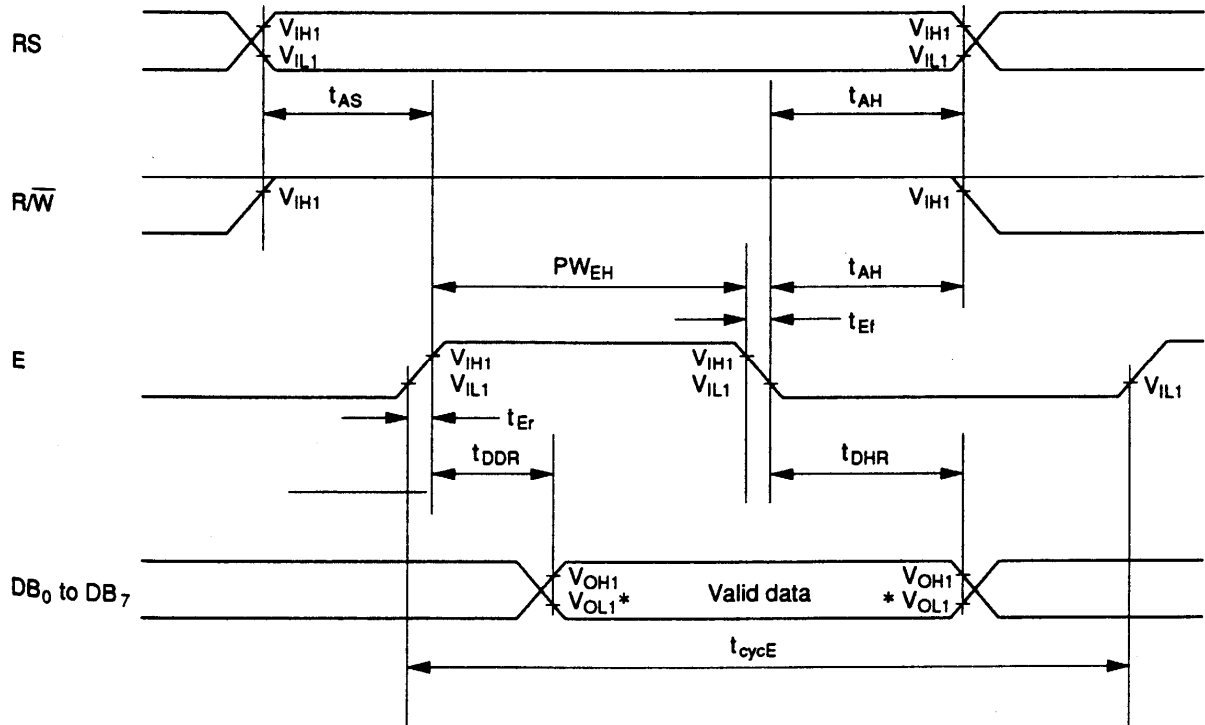

Item	Symbol	VDD=5V		Unit
		Min	Max	
Enable cycle time	tcycE	1200	--	ns
Enable pulse width	PWEH	140	--	
Enable rise/fall time	tEr,tEf	--	25	
Address set-up time (RS, R/W to E)	tAS	0	--	
Address hold time	tAH	10	--	
Data delay time	tDDR	--	100	
Data hold time	tDHR	10	--	

## 8 INSTRUCTION SET

Instruction	Code										Description	E.T.(fosc =270 KHZ)
	RS	R/ W	D7	D6	D5	D4	D3	D2	D1	D0		
Clear Display	0	0	0	0	0	0	0	0	0	1	Write"20H" to DDRAM and set DDRAM address to "00H" from AC	1.53 ms
Return Home	0	0	0	0	0	0	0	0	1	--	Sets DD RAM address to "00H" from AC and return cursor to its original position if shifted. The contents of DDRAM are not changed.	1.53 ms
Entry Mode SET	0	0	0	0	0	0	0	1	I/D	SH	Assign cursor moving direction and enable the shift of entire display.	39 μS
Display ON/OFF Control	0	0	0	0	0	0	1	D	C	B	Set display (D), cursor (C), and blink of cursor (B) on/off control bit.	39 μS
Cursor or Display Shift	0	0	0	0	0	1	S/ C	R/ L	--	--	Set cursor moving and display shift control bit, and the direction, without changing of DDRAM data.	39 μS
Function Set	0	0	0	0	1	DL	N	F	--	--	Sets interface data length (DL:8-bit/4-bit), number of display lines (N:2-line/1-line) and , display font type (F:5x11dots/5x8 dost).	39 μS
Set CG RAM Address	0	0	0	1	AC 5	AC 4	AC 3	AC 2	AC 1	AC 0	Sets CG RAM address in address counter.	39 μS
Set DD RAM Address	0	0	1	AC 6	AC 5	AC 4	AC 3	AC 2	AC 1	AC 0	Sets DD RAM address in address counter.	39 μS
Read Busy Flag and Address	0	1	BF	AC 6	AC 5	AC 4	AC 3	AC 2	AC 1	AC 0	Whether during internal operation or not can be known by reading BF. The contents of address counter can also be read.	0 μS
Write Data to RAM	1	0	D7	D6	D5	D4	D3	D2	D1	D0	Writes data into internal RAM (DD RAM /CG RAM).	43 μS
Read Data from RAM	1	1	D7	D6	D5	D4	D3	D2	D1	D0	Reads data from internal RAM (DD RAM /CG RAM).	43 μS

\* "--" : don't care

Note : When an MPU program with checking the Busy Flag(DB7) is made, it must be necessary 1/2Fosc is necessary for executing the next instruction by the falling edge of the 'E' signal after the Busy Flag(DB7) goes to "LOW".

## 9 INITIALIZATION SEQUENCE

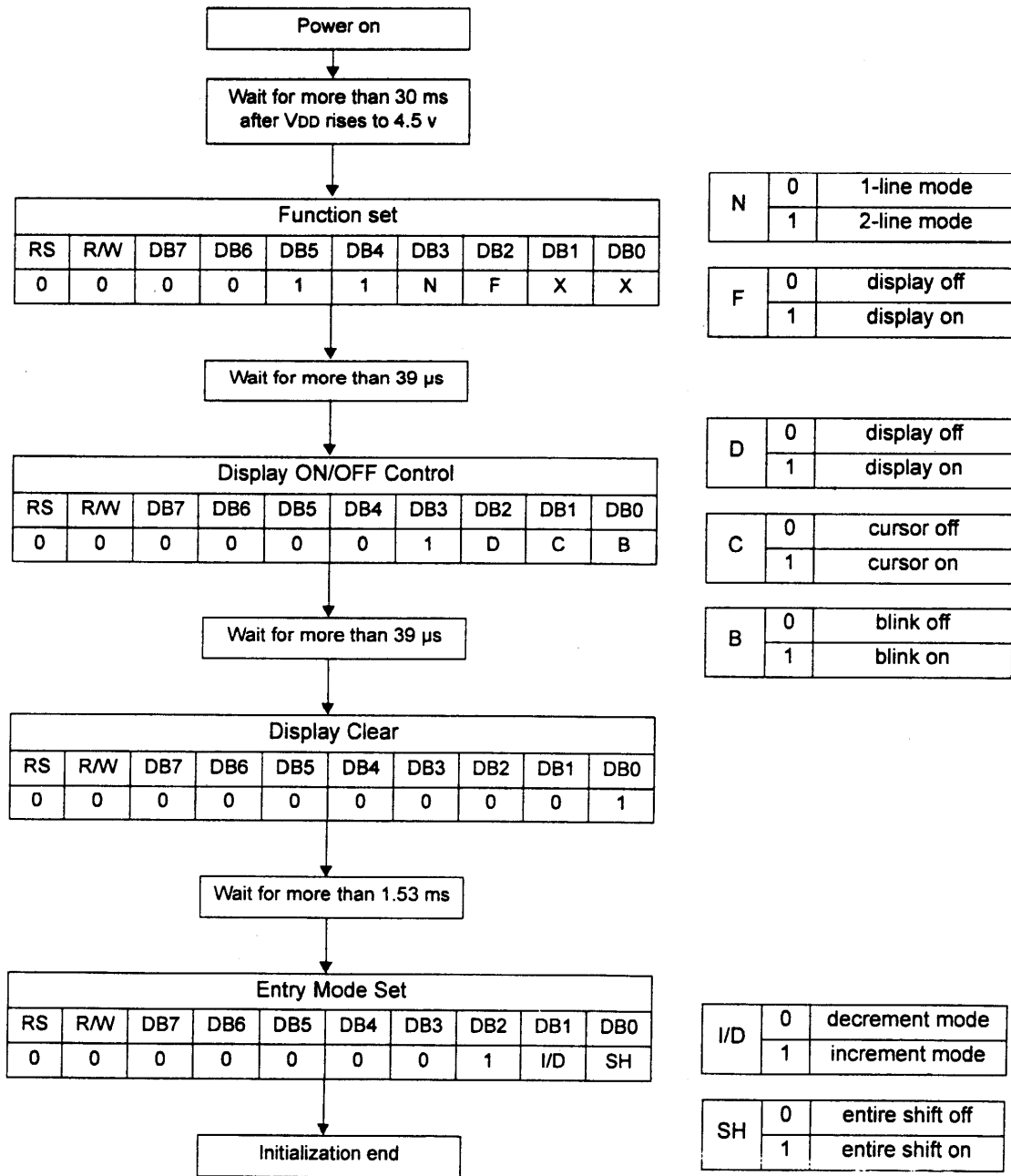

## 10 DD RAM ADDRESS

DIGIT	1	2	3	4	5	6	7	8	9	10	11	12	13	14	15	16
1 LINE	00	01	02	03	04	05	06	07	40	41	42	43	44	45	46	47

Display Position  
DD RAM Address

# 11 FONT TABLE

Upper 4bit Lower 4bit	LLLL	LLLH	LLHL	LLHH	LHLL	LHLH	LHLL	LHHH	HLLL	HLLH	HLHL	HLHH	HLLL	HLLH	HHLH	HHLH	HHLL	HHHL	HHHH					
	LLLL	CG RAM (1)	(2)	(3)	(4)	(5)	(6)	(7)	(8)	(1)	(2)	(3)	(4)	(5)	(6)	(7)	(8)	(1)	(2)	(3)	(4)	(5)	(6)	(7)

## **12 QUALITY AND RELIABILITY**

### **12.1 TEST CONDITIONS**

Tests should be conducted under the following conditions :

Ambient temperature :  $25 \pm 5^{\circ}\text{C}$

Humidity :  $60 \pm 25\% \text{ RH}$ .

### **12.2 SAMPLING PLAN**

Sampling method shall be in accordance with MIL-STD-105E , level II, normal single sampling plan .

### **12.3 ACCEPTABLE QUALITY LEVEL**

A major defect is defined as one that could cause failure to or materially reduce the usability of the unit for its intended purpose. A minor defect is one that does not materially reduce the usability of the unit for its intended purpose or is an infringement from established standards and has no significant bearing on its effective use or operation.

### **12.4 APPEARANCE**

An appearance test should be conducted by human sight at approximately 30 cm distance from the LCD module under fluorescent light. The inspection area of LCD panel shall be within the range of following limits.

## 12.5 INSPECTION QUALITY CRITERIA

Item	Description of defects			Class of Defects	Acceptable level (%)
Function	Short circuit or Pattern cut			Major	0.65
Dimension	Deviation from drawings			Major	1.5
Black spots	Ave . dia . D	area A	area B	Minor	2.5
	$D \leq 0.2$	Disregard			
	$0.2 < D \leq 0.3$	3	4		
	$0.3 < D \leq 0.4$	2	3		
	$0.4 < D$	0	1		
Black lines	Width W, Length L	A	B	Minor	2.5
	$W \leq 0.03$	disregard			
	$0.03 < W \leq 0.05$	3	4		
	$0.05 < W \leq 0.07, L \leq 3.0$	1	1		
	See line criteria				
Bubbles in polarizer	Average diameter D $0.2 < D < 0.5$ mm for N = 4 , D > 0.5 for N = 1			Minor	2.5
Color uniformity	Rainbow color or newton ring.			Minor	2.5
Glass Scratches	Obvious visible damage.			Minor	2.5
Contrast ratio	See note 1			Minor	2.5
Response time	See note 2			Minor	2.5
Viewing angle	See note 3			Minor	2.5

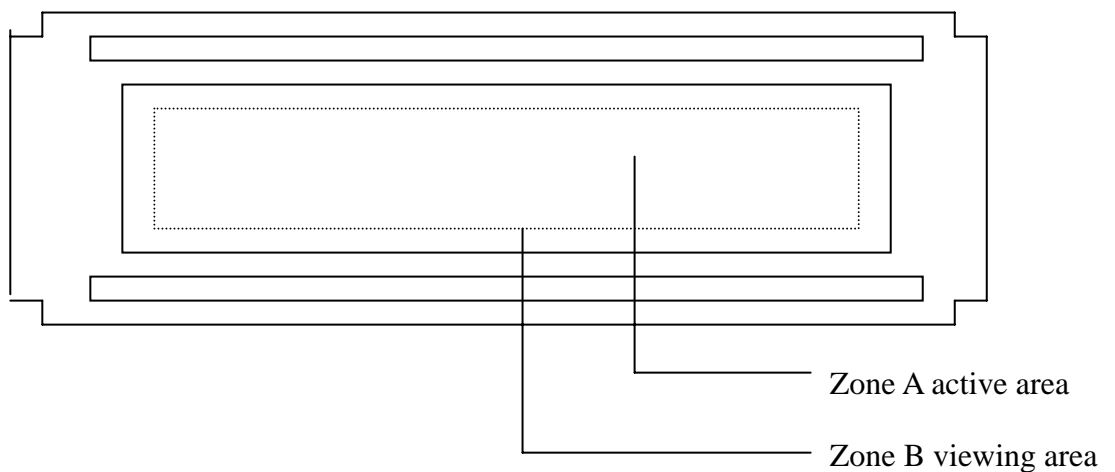

## 12.6 RELIABILITY

Test Item	Test Conditions	Note
	Extened Temp. type	
High Temperature Operation	70±3°C , t=96 hrs	
Low Temperature Operation	-20±3°C , t=96 hrs	
High Temperature Storage	80±3°C , t=96 hrs	1,2
Low Temperature Storage	-30±3°C , t=96 hrs	1,2
Temperature Cycle	-20°C ~ 25°C ~ 70°C 30 m in. 5 min. 30 min. ( 1 cycle ) Total 5 cycle	1,2
Humidity Test	40 °C, Humidity 90%, 96 hrs	1,2
Vibration Test (Packing)	Sweep frequency : 10 ~ 55 ~ 10 Hz/1min Amplitude : 0.75mm Test direction : X.Y.Z/3 axis Duration : 30min/each axis	2

Note 1 : Condensation of water is not permitted on the module.

Note 2 : The module should be inspected after 1 hour storage in normal conditions  
(15-35°C , 45-65%RH).

Definitions of life end point :

Current drain should be smaller than the specific value.

Function of the module should be maintained.

Appearance and display quality should not have degraded noticeably.

Contrast ratio should be greater than 50% of the initial value.

### **13 HANDLING PRECAUTIONS**

A LCD module is a fragile item and should not be subjected to strong mechanical shocks.

Avoid applying pressure to the module surface. This will distort the glass and cause a change in color.

Under no circumstances should the position of the bezel tabs or their shape be modified.

Do not modify the display PCB in either shape or positioning of components.

Do not modify or move location of the zebra or heat seal connectors.

The device should only be soldered to during interfacing. Modification to other areas of the board should not be carried out.

In the event of LCD breakage and resultant leakage of fluid do not inhale, ingest or make contact with the skin. If contact is made rinse immediately.

When cleaning the module use a soft damp cloth with a mild solvent, such as Isopropyl or Ethyl alcohol. The use of water, ketone or aromatic is not permitted.

Prior to initial power up input signals should not be applied.

Protect the module against static electricity and observe appropriate anti-static precautions.



# 14 OUTLINE DIMENSION

